

# OPTIMAL PURCHASE AND SALE OF ENERGY IN ELECTRICITY MARKETS DUE TO VARIOUS UNCERTAINTIES IN MICROGRID

MAHDIRAJI, E. A.

*Department of Engineering, Islamic Azad University, Sari, Iran.  
e-mail: ebad.amouzad[at]gmail.com*

(Received 25<sup>th</sup> December 2021; accepted 20<sup>th</sup> March 2022)

**Abstract.** Given that different energy carriers affect each other and that a plan to smarten power grids will be implemented in the future, one of the fundamental questions is how to integrate these systems. Therefore, in this case, the creation of organized (integrated) energy markets, i.e. electricity, gas, or other energy carrier markets is required, and the effects of these carriers on each other and on the energy market should be examined. Therefore, one of the main discussions is how to integrate these systems with centralized control. For this reason, it is necessary to examine one micro-grid or several micro-grids separately and the synergy of these micro-grids should also be examined. The main purpose is to create a framework for modeling a set of multi-carrier micro-grids to determine the optimal purchase and sale of energy in the markets of the day-before and the market-real-time due to various uncertainties in micro-grids. In this paper, it is possible to study the balance between different energy carriers in several micro-grids to provide the energy needed by consumers to supply different types of loads and energy interactions between several micro-grids and energy carriers with the approach of providing energy with the lowest cost. The possibility of planning in energy supply by considering different energy markets. This dissertation is a strategy proposing the optimal purchase and sale of electricity and gas as well as the simultaneous effects of gas and electricity prices on the previous day market and real-time (instantaneous) market for several micro-grids consisting of distributed generation, renewable generation, cogeneration power plants.

**Keywords:** *uncertainty, two-step model, scenario reduction, energy market, operation*

## Introduction

Micro-networks now have access to the commercial markets they have created from laboratory locations and pilot demonstrations, with technological advances, cost reductions, a well-established track record, and growing recognition. Microgrids are used to improve the reliability and flexibility of power grids so that in addition to distributing clean energy sources such as wind and photovoltaics, they can also manage the reduction of fossil fuel emissions and power supply in areas that do not have centralized electricity infrastructure. Recently, the world's power systems have begun to "decentralize" from bottom to top in many cases. These trends require strengthening electricity costs, replacing worn-out infrastructure, improving resilience and reliability, reducing greenhouse gas emissions to mitigate climate change, and providing reliable electricity to areas without electricity infrastructure (Amouzad Mahdiraji, 2020a; Amouzad Mahdiraji and Ramezani, 2020; Hirsch et al., 2018). While the balance of factors and details in a particular way may vary from place to place, microgrids are emerging as a flexible structure for utilizing distributed energy sources that can meet the broad needs of different communities at large from cities to villages. However, these benefits seem to have reached their limits and are increasingly being undermined due to environmental and economic concerns.

Gradually, with the transformation of power companies, using advanced technologies of distributed energy sources and economic risks, the construction of huge power plant facilities, and transmission infrastructure, they become smaller and decentralized units.

Their solution is a grid structure that can control the production and demand of electricity locally under sub-segments of the grid that can be automatically separated from the larger grid so that even in the event of a global grid failure, services provide critical conditions (Mahdiraji, 2020a; Williams et al., 2015; Kuznetsova et al., 2014). Significant changes are taking place in energy infrastructure today. With the gradual increase in fuel prices and the depletion of energy production infrastructure, the increase in multiple energy consumption has caused concern. To solve this problem, the use of decentralized energy sources such as high-efficiency small-scale energy sources, load management programs in the structure of existing energy systems should be increased instead of high-cost investments. In addition, privatization and restructuring of the electricity industry about new legislation and technologies are happening rapidly. Increasing the energy efficiency of the industrial and commercial sectors and the decentralized development of the production, transmission, and distribution sectors are among the advantages of privatization. As a result, the integration of distributed generation in the distribution network prevents the development of transmission lines and the construction of power plants with high investment costs.

One of the main concepts in privatization is microgrids that can compete with traditional central power plants by providing an acceptable level of reliability and quality power to end subscribers, error resistance, cost, and low pollution. In the future, microgrids may include distributed generation and controllable and uncontrollable loads, which are defined as a range of energy that operates independently of the main network. Traditionally, infrastructures for the supply of electrical, thermal, and chemical energy have been studied independently, while new technologies have led to the study of different energy carriers in recent decades due to the simultaneous production of two or three carriers simultaneously (Mahdiraji and Amiri, 2021a; Amouzad Mahdiraji, 2020b; Xia et al., 2013). Gas-fired units have been a major factor in increasing gas consumption in many countries. Gas consumption is increasing due to economic and local benefits. Therefore, it is likely that the peak load will be transferred from the electricity grid to the gas grid, because the production of electricity from natural gas may be economically significant instead of consuming electricity directly from the grid at certain hours. In addition, generating electricity from small-scale sources typically involves various forms of energy, such as thermal and chemical. Therefore, the analysis of the power grid should include a wide range of different energies to operate and plan strategies (Mahdiraji et al., 2021a; Zhang et al., 2016; Bao et al., 2014; Olsina et al., 2014).

Integration of different energy supply systems increases the energy efficiency and reliability of the energy system. Intelligent microgrids are an ideal area for the use of multi-energy microgrids and provide a framework for the optimal daily planning of a multi-energy microgrid system. The proposed framework optimizes the cost of the daily operation of multi-carrier microgrid systems due to existing uncertainties (Mahdiraji and Amiri, 2021b; Mahdiraji et al., 2021b; Gerard et al., 2018; Kim et al., 2016; Mahdiraji and Ramezani, 2016). Multi-carrier microgrids provide simultaneous operation of several networks of different carriers and sources of production of different energy carriers by considering the effects of these carriers and taking into account the uncertainties on each other and the possibility of optimal operation with more flexibility. The main purpose of this paper is a framework for modeling a set of multi-carrier microgrids to determine the optimal amount of energy buying and selling in the markets of the day-before and the market of time-due to various uncertainties in

microgrids. In this dissertation, it is possible to study the balance between different energy carriers in several microgrids to supply the energy needed by consumers in supplying different types of loads and energy interactions between several microgrids and energy carriers with the approach of providing energy with the lowest cost. The possibility of planning in energy supply by considering different energy markets.

### ***Multi-carrier microgrid***

From the consumer's point of view, microgrids are like traditional distribution networks that generate energy. To achieve synergy and high energy efficiency in the simultaneous analysis of different energy carriers, it is very important to apply the concept of multi-carrier energy to model microgrids. Multi-carrier microgrids are introduced as an interconnected electricity and gas distribution network. Electrical networks are a combination of an interconnected group of electricity demand and distributed energy sources that form a single controllable entity with an electrical network that can be exploited. Provides in network connection mode and offline. The natural gas distribution network in the microgrid is a combination of several sources that are connected to the gas network and a group of loads that provide units of electricity generation or heat demand (Urbanucci et al., 2018). Intelligent microgrids are an ideal area for using multimode energy sources. Multi-port energy microgrid systems can use energy resources economically and efficiently (Bao et al., 2019). In contrast to conventional single-carrier microgrids, consumers in multi-carrier microgrids can receive power simultaneously in the microgrid. In addition, multi-port power grids have the advantage that they can power energy consumers using different types of inputs. Consumers in this activity see the essentials of energy; however, in terms of multi-carrier microgrids, the consumer-related energy delivery method can be converted to other energy carriers by interdependent energy equipment. In a microgrid system, the problem of microgrid energy planning plays an essential role in operation (Mahdiraji, 2020b; Xu et al., 2014). Multipolar microgrids compare energy with a single microgrid energy carrier because it is a more complex system and must plan different types of energy together (*Figure 1*). In addition, in a multi-carrier microgrid system, each energy carrier has a unique characteristic that is different from other energy carriers (*Figure 2*).

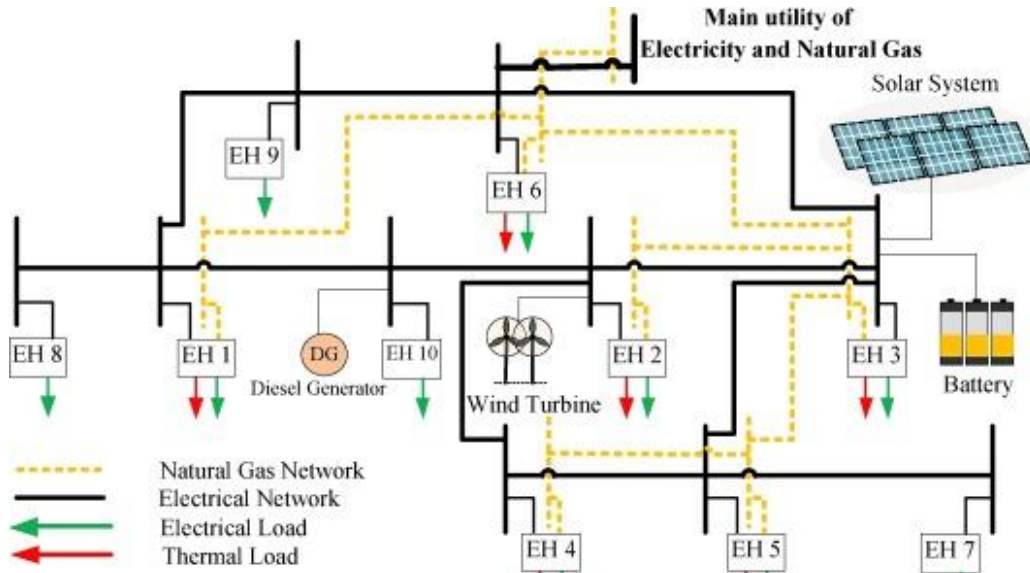


Figure 1. A typical multi-carrier microgrid.

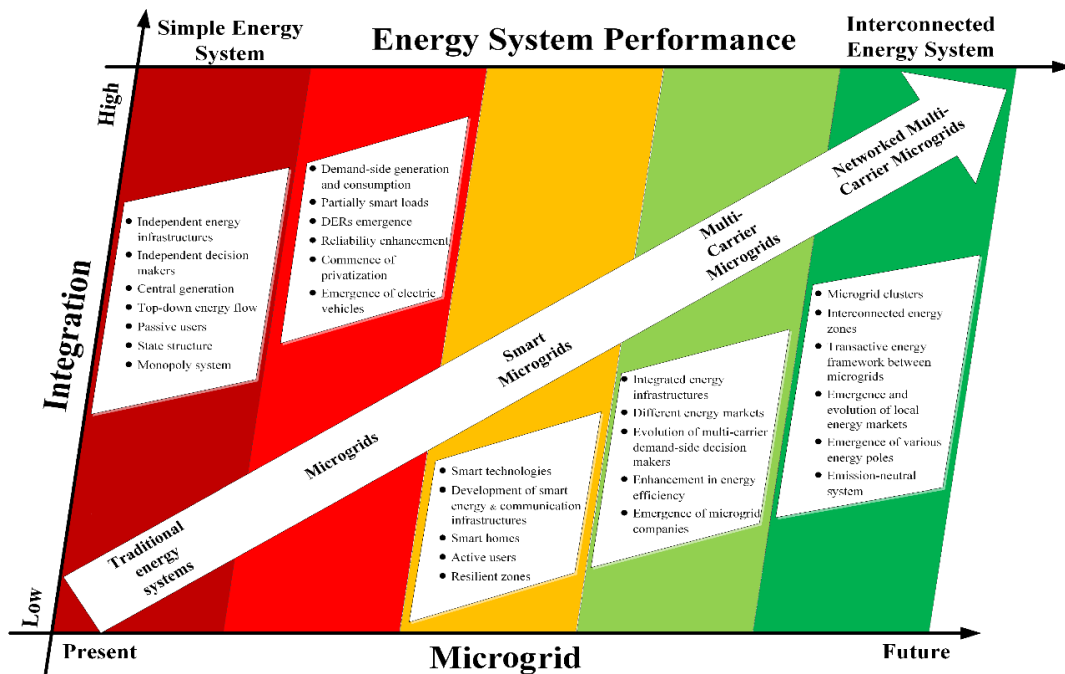


Figure 2. The evolution of multi-carrier microgrids of energy.

### Energy markets

The study of the economic growth and development of industrialized countries indicates the undeniable role of energy resources as the driving force of this process. Following the Industrial Revolution, coal, as the main source of energy of that period, played an irreplaceable role in the industrial development of Western countries. With the discovery of oil and due to the more distinctive properties of this fuel compared to coal-including ease of transportation and higher calorific value-another dramatic change occurred in the human environment and oil played a role as the driving force of large economies. Natural gas, especially since the twentieth century, as one of the almost

clean fuels in the category of fossil fuels, has a significant share of the world's consumer basket. It should be noted that after the oil shock of 1973 and the establishment of the International Energy Agency, extensive efforts have been made by industrialized countries to reduce their dependence on fossil fuels, including oil; For example, planning for the development of renewable energy sources such as solar, wind, hydroelectric, geothermal and biomass are examples of these efforts that could lead to more use of this type of energy in the future. However, despite many efforts to reduce dependence on fossil fuels, the predictions of most major energy market analysts show that in the foreseeable future, fossil fuels, particularly oil and gas, will continue to be the main fuel in the basket.

Energy consumption will be considered in the world. Due to the undeniable importance of energy in the development and progress of societies, energy security has an important place in the economic and political policies of countries. Indeed, the importance of energy security in today's world has led to a wide-ranging interaction between energy and politics, and many of the world's friendships, rivalries, and political developments are influenced by energy and the issues surrounding it. From the consumers' point of view, the concept of energy security means ensuring easy access to energy resources, stabilizing energy-exporting areas, risk-free transfer to target markets, and reasonable prices, so that in the long run there is no concern for energy supply in critical situations. To achieve this, by creating energy markets and policies such as geographical diversification for energy supply, diversification of energy transmission routes, efforts to increase production and management to control prices, is on the agenda of this group of countries. The energy market is a system for buying and selling electricity in the form of supply and demand, which is set up to determine the price of energy carriers. In the new structure, unlike the old structure where production, distribution, and transmission management were single management, the mentioned systems operate independently (Mahdiraji, 2020; Davatgaran et al., 2018; Hong et al., 2017; Prodan and Zio, 2014; Basu et al., 2010).

## **Materials and Methods**

### ***Modeling and problem description***

In this section, the problem of optimal operation of a set of multi-carrier microgrids is modeled by considering uncertainties. Defined and presented by solving two problems. Initially, this modeling is performed to solve the problem of optimal operation in a multi-carrier microgrid by considering the uncertainties in renewable energy, thermal and electrical loads, and day-to-day and real-time markets (Li and Xu, 2019). Optimal operation of several multicore microgrids is presented by considering the uncertainties in photovoltaic and wind energies, electrical and thermal loads, and the markets of the day before and in real-time, as well as the effects of islanding of microgrids on each other and the upstream grid. These problems are solved as an integer linear model by GAMS software and the scenario reduction method. A multi-carrier microgrid of energy from a medium or low voltage power grid alongside a network of other energy carriers including gas and heat, which is assisted by a series of converters including distributed generation sources, heat exchangers, and heat and power generation sources. It allows the conversion of energy from one state to another. This network can be connected to the main network of energy carriers such as electricity, heat, and gas. In addition to these converters, the presence of distributed energy sources,



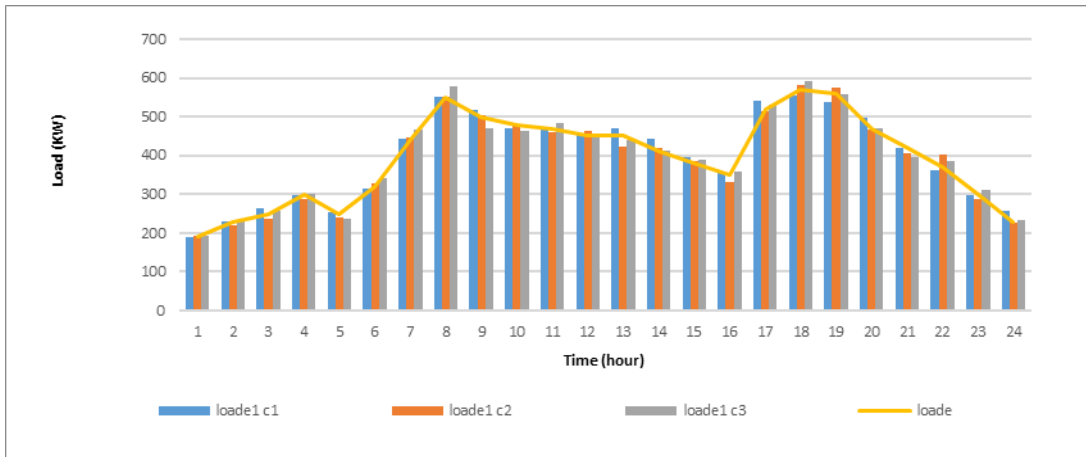


Figure 4. Electric charge curve.

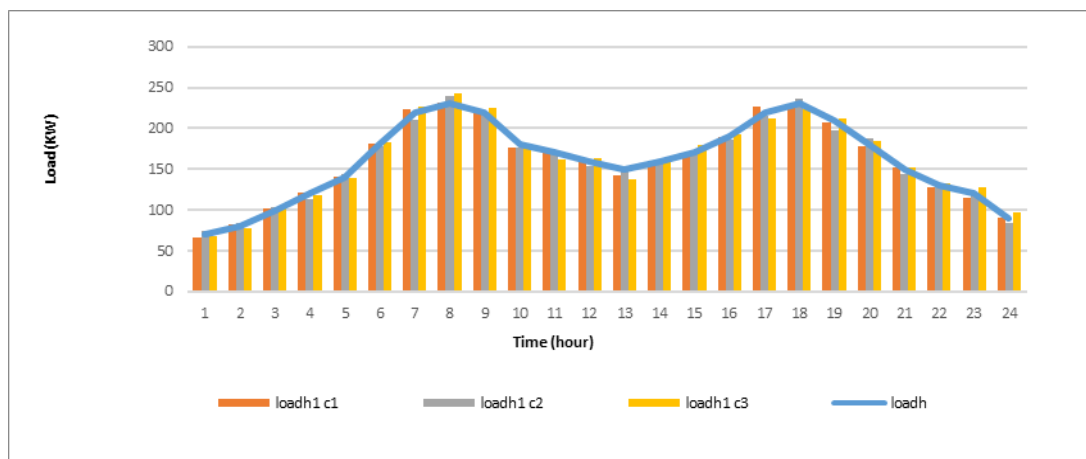
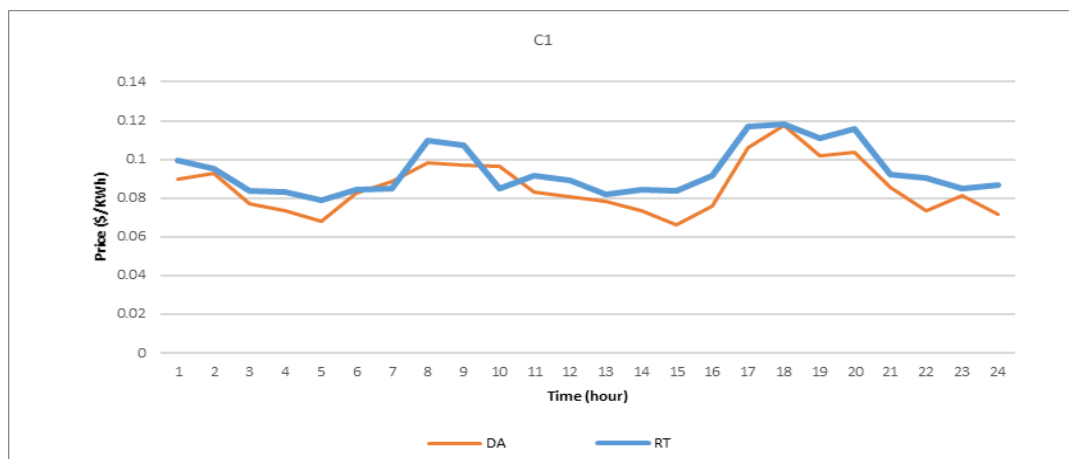
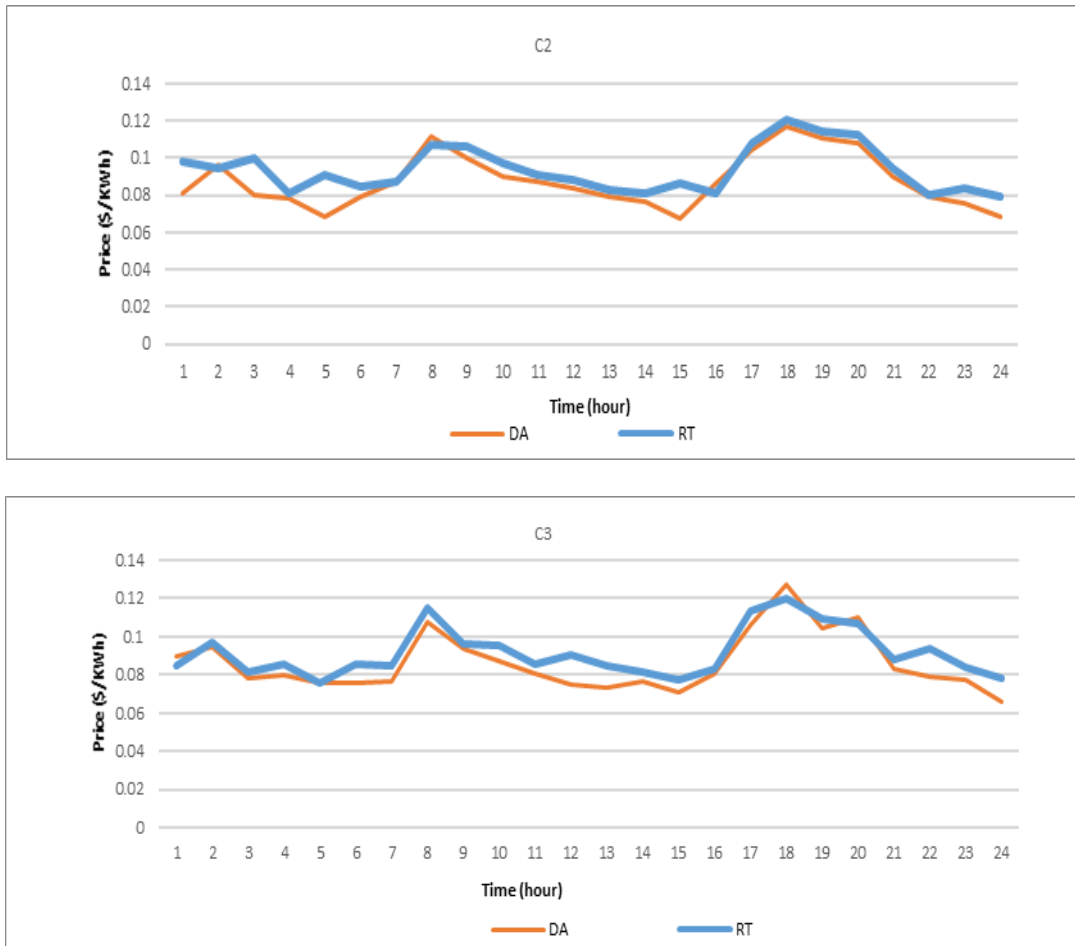


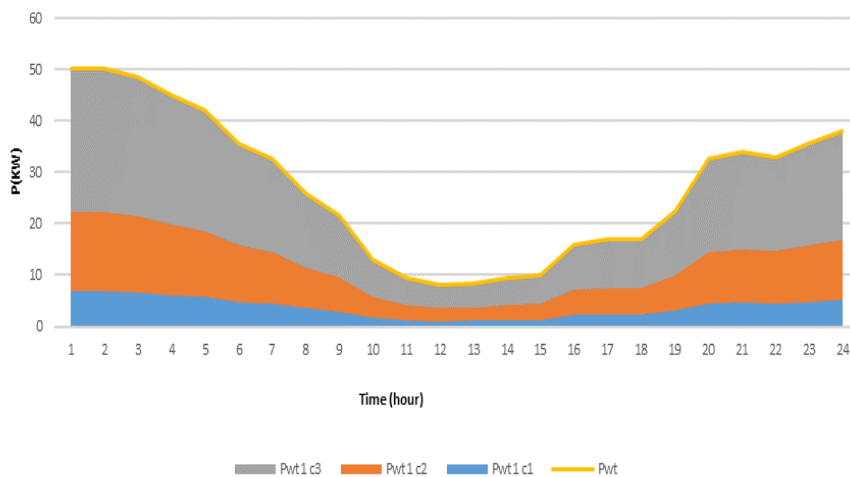
Figure 5. Thermal charge curve.



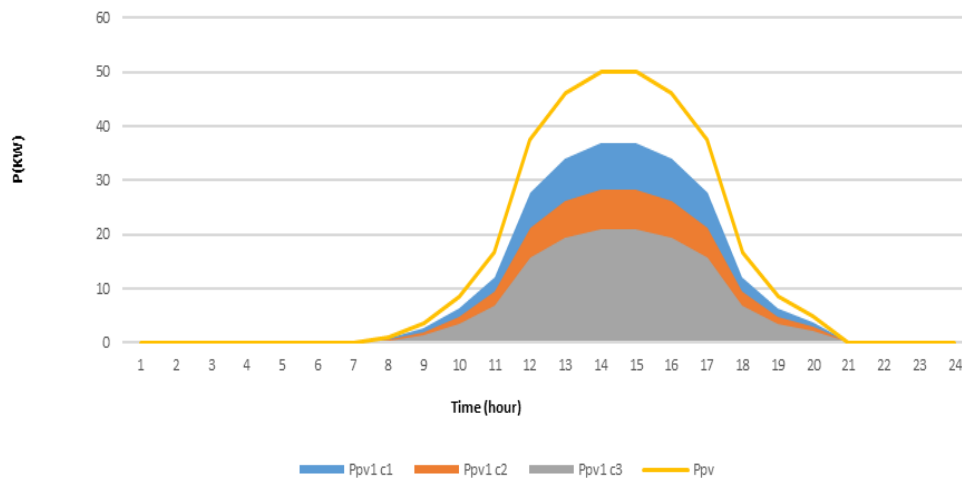


**Figure 6.** Electricity prices in the previous day and moment modes for three scenarios of C1, C2 and C3.

The production of solar and wind units for each scenario is shown in *Figure 7* and *Figure 8*.



**Figure 7.** Graph of wind power plant production.



*Figure 8. Graph of the amount of solar power plant production.*

## Conclusion

The proposed model for simulating the optimal operation of a multi-carrier microgrid considering uncertainties examines a two-stage model of day-to-day and real-time market participation to provide electrical and thermal loads and deal with existing uncertainties to reduce microgrid operating costs. The results of the proposed model show the effect of simultaneous participation in the day-to-day and real-time market of multi-port microgrids and its advantages. The results show that the cost of operating the microgrid has decreased by about 2.5% with simultaneous participation in the day-before and real-time market compared to participation in the real-time market alone. It is shown that when all the uncertainties are taken into account, the microgrid is more inclined to buy energy in the day-before market due to the cheapness of electricity and to sell energy in the real-time market due to the higher price. Increasing the capacity and capacity of the battery in the microgrid has a significant impact on reducing the cost of operating the microgrid in real-time.

## Acknowledgement

This research study is self-funded.

## Conflict of interest

The author confirm there are no conflict of interest involve with any parties in this research study.

## REFERENCES

- [1] Amouzad Mahdiraji, E. (2020a): Optimal Switching of Micro-grid Distributed Management based on Equilibrium Models. – Signal Processing and Renewable Energy 4(3): 67-80.

- [2] Amouzad Mahdiraji, E. (2020b): Time-Based Development Plans for Distribution Networks in the Presence of Distributed Generators and Capacitor Banks. – *Journal of Scientific Perspectives* 4(4): 245-254.
- [3] Amouzad Mahdiraji, E., Ramezani, N. (2020): Optimal in Smart Grids Considering Interruptible Loads and Photo-voltaic Sources Using Genetic Optimization. – *Signal Processing and Renewable Energy* 4(1): 37-50.
- [4] Bao, Z., Zhou, Q., Yang, Z., Yang, Q., Xu, L., Wu, T. (2014): A multi time-scale and multi energy-type coordinated microgrid scheduling solution—Part II: Optimization algorithm and case studies. – *IEEE Transactions on Power Systems* 30(5): 2267-2277.
- [5] Basu, A.K., Chowdhury, S., Chowdhury, S.P. (2010): Impact of strategic deployment of CHP-based DERs on microgrid reliability. – *IEEE Transactions on Power Delivery* 25(3): 1697-1705.
- [6] Davatgaran, V., Saniei, M., Mortazavi, S.S. (2018): Optimal bidding strategy for an energy hub in energy market. – *Energy* 148: 482-493.
- [7] Gerard, H., Puente, E.I.R., Six, D. (2018): Coordination between transmission and distribution system operators in the electricity sector: A conceptual framework. – *Utilities Policy* 50: 40-48.
- [8] Hirsch, A., Parag, Y., Guerrero, J. (2018): Microgrids: A review of technologies, key drivers, and outstanding issues. – *Renewable and Sustainable Energy Reviews* 90: 402-411.
- [9] Hong, Y.Y., Chang, W.C., Chang, Y.R., Lee, Y.D., Ouyang, D.C. (2017): Optimal sizing of renewable energy generations in a community microgrid using Markov model. – *Energy* 135: 68-74.
- [10] Kim, S.W., Kim, J., Jin, Y.G., Yoon, Y.T. (2016): Optimal bidding strategy for renewable microgrid with active network management. – *Energies* 9(1): 15p.
- [11] Kuznetsova, E., Li, Y.F., Ruiz, C., Zio, E. (2014): An integrated framework of agent-based modelling and robust optimization for microgrid energy management. – *Applied Energy* 129: 70-88.
- [12] Li, Z., Xu, Y. (2019): Temporally-coordinated optimal operation of a multi-energy microgrid under diverse uncertainties. – *Applied Energy* 240: 719-729.
- [13] Mahdiraji, E.A. (2020a): Introducing a New Method to Increase Critical Clearing Time (CCT) and Improve Transient Stability of Synchronous Generator Using Brake Resistance. – *Gazi Mühendislik Bilimleri Dergisi (GMBD)* 6(2): 138-144.
- [14] Mahdiraji, E.A. (2020b): Investigation of Overvoltages Caused by Lightning Strikes on Transmission Lines and GIS Substation Equipment. – *Computational Research Progress in Applied Science & Engineering (CRPASE)* 6(4): 238-244.
- [15] Mahdiraji, E.A., Amiri, M.S. (2021a): Market Clearing due to the Reliability of Electricity Generation Units. – *Advanced Journal of Science and Engineering* 2(1): 42-50.
- [16] Mahdiraji, E.A., Amiri, M.S. (2021b): Optimization of Electric Vehicles Along with Power Generation Units to Improve Microgrid Reliability. – *Quantum Journal of Engineering, Science and Technology* 2(2): 1-15.
- [17] Mahdiraji, E.A., Ramezani, N. (2016): The Influences of Soil Ionization in the Grounding System and Corona Phenomena on the Injection Lightning Current of 1000 KV UHV Transmission Line. – *International Academic Journal of Science and Technology* 3(9): 1-12.
- [18] Mahdiraji, E.A., Amiri, M.S., Shariatmadar, S.M. (2021a): VOLTAGE LOAD SHEDDING CONSIDERING VOLTAGE SENSITIVITY AND REACTIVE POWER. – *Quantum Journal of Engineering, Science and Technology* 2(6): 55-72.
- [19] Mahdiraji, E.A., Amiri, M.S., Shariatmadar, S.M. (2021b): ANALYSIS OF LIGHTNING STRIKES ON THE TRANSMISSION LINE BY CONSIDERING THE FREQUENCY-DEPENDENT MODEL. – *Quantum Journal of Engineering, Science and Technology* 2(6): 12-36.

- [20] Olsina, F., Pringles, R., Larisson, C., Garcés, F. (2014): Reliability payments to generation capacity in electricity markets. – *Energy Policy* 73: 211-224.
- [21] Prodan, I., Zio, E. (2014): A model predictive control framework for reliable microgrid energy management. – *International Journal of Electrical Power & Energy Systems* 61: 399-409.
- [22] Urbanucci, L., Testi, D., Bruno, J.C. (2018): An operational optimization method for a complex polygeneration plant based on real-time measurements. – *Energy Conversion and Management* 170: 50-61.
- [23] Williams, N.J., Jaramillo, P., Taneja, J., Ustun, T.S. (2015): Enabling private sector investment in microgrid-based rural electrification in developing countries: A review. – *Renewable and Sustainable Energy Reviews* 52: 1268-1281.
- [24] Xia, Y., Ghiocel, S.G., Dotta, D., Shawhan, D., Kindle, A., Chow, J.H. (2013): A simultaneous perturbation approach for solving economic dispatch problems with emission, storage, and network constraints. – *IEEE Transactions on Smart Grid* 4(4): 2356-2363.
- [25] Xu, Y., Zhang, W., Liu, W. (2014): Distributed dynamic programming-based approach for economic dispatch in smart grids. – *IEEE Transactions on Industrial Informatics* 11(1): 166-175.
- [26] Zhang, C., Wang, Q., Wang, J., Korpås, M., Pinson, P., Østergaard, J., Khodayar, M.E. (2016): Trading strategies for distribution company with stochastic distributed energy resources. – *Applied Energy* 177: 625-635.